

ZHS-0208 IRCUT

ISO/TS16949 ISO9000 ISO14000
RoHS REACH CE UL VDE TÜV

ZHS-0208

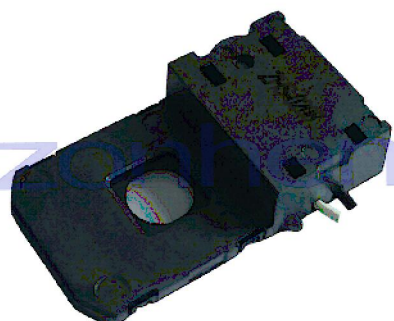

总重量 Total Weight: 7g
应用范围: CMOS和CCD摄像机
APPLICATION: The Door IP Intercom

综合特性

GENERAL FEATURES

1. 驱动类型: 励磁式
Motor Type: Magnet moving
2. 工作电压: DC 3.3-6V
Work Voltage : DC 3.3-6V
3. 工作环境温度:
温度: -30~80℃
湿度: 0~90%
Operating environment:
Temp: -30~80℃
Relative humidity: 0~90%
4. 滤光片切换响应时间: 50ms
Fluid medium: Air, volati
5. 寿命: 典型值为10万次 (on 0.1s, off 3s)
Lify cycle: 1,000, 00 cycles (on 0.1s, off 3s)
6. 绝缘等级: B类
Insulation class: class B
7. 安装CCD和CMOS芯片的镜头座可以提供不同规格, 并可以按客户要求定做.

类型: 抽屜式

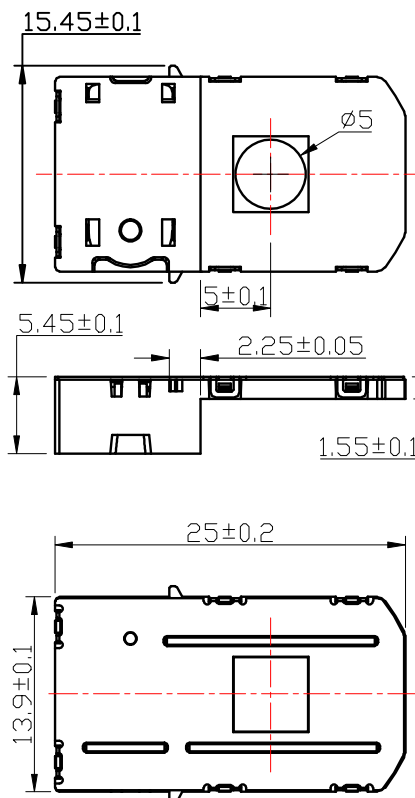

单位:mm Units:mm

轴测图

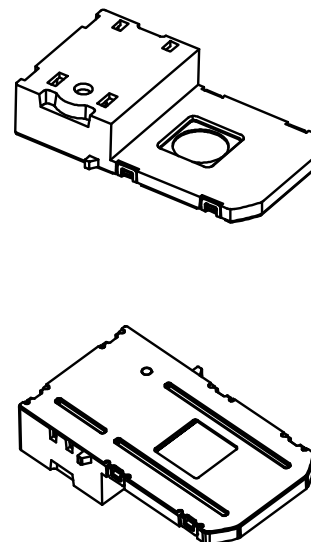

镜片光谱图

1. IR Filter spectrum :

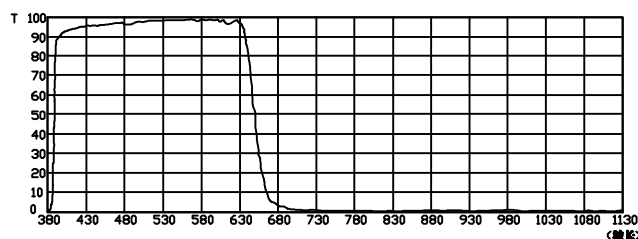

2. AR Filter spectrum :

